

[See all 7 Products in Family](#)

1" Travel, 2.62"L x 2.62"W Ball Bearing Slide



Linear Motion Ball Bearing Slides



Stock #37-356 **5 In Stock**

⊖ 1 ⊕ **\$\$438²⁰**

ADD TO CART

Volume Pricing	
Qty 1+	\$\$438.20 each
Need More?	Request Quote

Product Downloads

General

English **Type:**

Physical & Mechanical Properties

Linear (X) **Type of Movement:**

Ball Bearing **Guide System:**

66.5 x 66.5	Stage Size (mm):
1	Travel (inches):
Construction: Aluminum Top and Base/440C Stainless Steel Bearings	
1.00	Height (inches):
40.0	Load Capacity, Normal (lbs):
(2) #1/4 on Base	S.H.C.S. C'bore:
2.62 x 2.62	Stage Size (inches):
0.00008/inch of travel	Straight Line Accuracy (inches):
0.6	Weight (lbs):

Hardware & Interface Connectivity

Manual	Type of Drive:
--------	-----------------------

Threading & Mounting

(8) 10-32 on Top	Mounting Threads:
------------------	--------------------------

Regulatory Compliance

Compliant	RoHS 2015:
View	Certificate of Conformance:

Product Details

- High Straight Line Accuracy
- Low Wear, Low Friction Sliding Motion
- Preloaded to Eliminate Wobble and Unwanted Play

Linear Motion Ball Bearing Slides are mechanically simple linear motion devices comprised of a stationary base with a mobile carriage riding on top. One row of hardened steel balls on each side of the base provides the accurate, low-friction sliding motion between the stationary base and the top slide. Each row of bearings is contained between two hardened, precision steel rods. Linear Motion Ball Bearing Slides are preloaded to eliminate wobble and unwanted play in the system. Ball slides are functionally much more reliable than dovetail slides since there is no direct sliding contact between the top and bottom pieces. The slides also eliminate the rapid wear problems, regular lubrication requirements, and the skipping/jumping (caused by the increased force needed to initiate movement) that are characteristic of dovetail assemblies.

Technical Information

Dimensions (Inches)							Base Mounting Holes			Top Mounting Holes				Stock No.
Fig.	A	B	C	D	E	F	G	H	J	K	L	M	N	
B	0.59	1.12	0.32	0.24	0.24	1	0.19	0.75	#2	0.218	0.63	2-56	4	#53-849
B	0.59	2.12	0.32	0.24	0.24	1	0.37	1.38	#2	0.218	1.63	2-56	4	#53-850
B	1.00	1.68	0.50	0.36	0.36	1	0.22	1.25	#4	0.438	1.25	6-32	4	#53-853
A	2.62	2.62	1.00	1.48	0.61	-	0.31	2.00	#1/4	-	2.00	10-32	8	#37-356
B	1.75	3.00	0.75	0.88	0.40	5.00	0.31	2.38	#6	1.000	0.50	6-32	12	#37-361

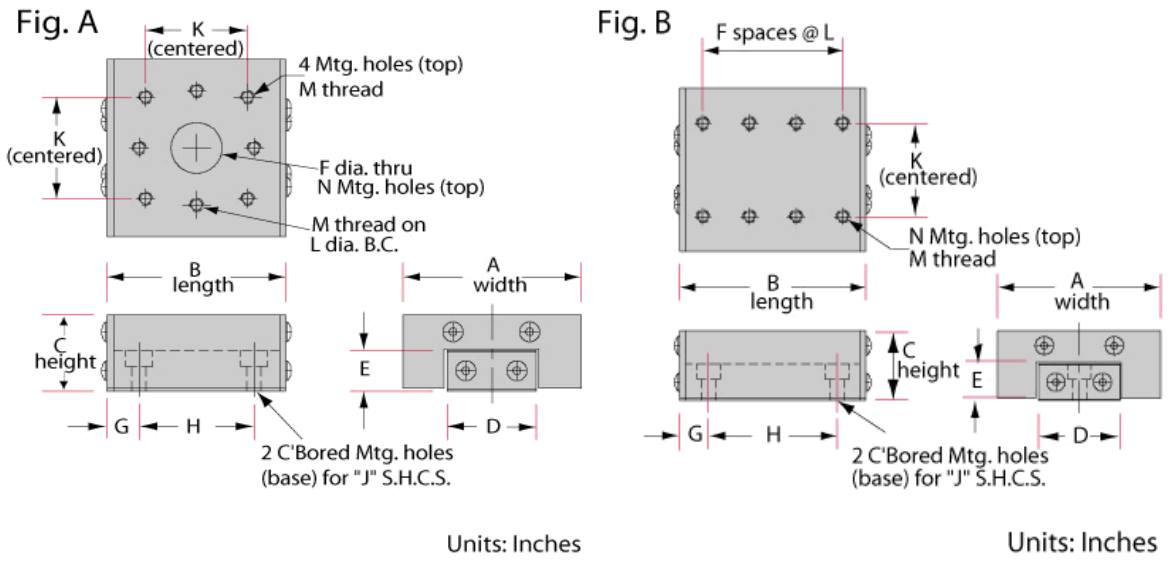

Units: Inches

Units: Inches

Type	A	B	C	D	E	F	G	Stock No.
Figure A	4"	0.69"	0.5"	6	-	-	-	#37-363
Figure A	5"	1.19"	1"					#37-364
Figure A	6"	1.69"	0.5"	10	1			#37-365
Figure B	9"	2"	3.5"	3	3	1.5"	8	#37-366
Figure B	12"		5"		5	1"	12	#37-367
Figure B	15"	4"	3.25"	5	6	1.5"	14	#37-368
Figure B	18"		4"		8	1"	18	#37-369

